



## Measurements of Photolyzable Halogen Compounds and Bromine Radicals during the Polar Sunrise Experiment 1997

G.A. IMPEY<sup>1</sup>, C.M. MIHELE<sup>2</sup>, K.G. ANLAUF<sup>2</sup>, L.A. BARRIE<sup>1,2</sup>,  
D.R. HASTIE<sup>1,\*</sup> and P.B. SHEPSON<sup>1,3</sup>

<sup>1</sup>Department of Chemistry and Centre for Atmospheric Chemistry, York University, Toronto, Canada

<sup>2</sup>Atmospheric Environment Service, Toronto, Canada

<sup>3</sup>Department of Chemistry and Department of Earth and Atmospheric Sciences, Purdue University, West Lafayette, Indiana

(Received: 17 July 1998; in the final form: 31 March 1999)

**Abstract.** As part of the Polar Sunrise Experiment (PSE) 1997, concentrations of halogen species thought to be involved in ground level Arctic ozone depletion were made at Alert, NWT, Canada (82.5°N, 62.3°W) during the months of March and April, 1997. Measurements were made of photolyzable chlorine (Cl<sub>2</sub> and HOCl) and bromine (Br<sub>2</sub> and HOBr) using the Photoactive Halogen Detector (PHD), and bromine radicals (BrO<sub>x</sub>) using a modified radical amplifier. During the sampling period between Julian Day 86 (March 27) and Day 102 (April 12), two ozone depletion episodes occurred, the most notable being on days 96–99, when ozone levels were below detectable limits (≈1 ppbv). Concentrations of BrO<sub>x</sub> above the 4 pptv detection limit were found for a significant part of the study, both during and outside of depletion events. The highest BrO<sub>x</sub> concentrations were observed at the end of the depletion event, when the concentration reached 15 pptv. We found substantial amounts of Br<sub>2</sub> in the absence of O<sub>3</sub>, indicating that O<sub>3</sub> is not a necessary requirement for production of Br<sub>2</sub>. There is also Br<sub>2</sub> present when winds are from the south, implying local scale (e.g. from the snowpack) production. During the principal O<sub>3</sub> depletion event, the HOBr concentration rose to ≈260 pptv, coincident with the BrO<sub>x</sub> maximum. This implies a steady state HO<sub>2</sub> concentration of 6 pptv. During a partial O<sub>3</sub> depletion event, we estimate that the flux of Br<sub>2</sub> from the surface is about 10 times greater than that for Cl<sub>2</sub>.

**Key words:** Br<sub>2</sub>, HOBr, BrO<sub>x</sub>, Arctic, ozone depletion, troposphere.

### 1. Introduction

The frequent, sudden decrease in surface ozone in the Arctic regions in the spring (Bottenheim *et al.*, 1986) is still only a partly explained observation. Evidence is mounting for the importance of halogen chemistry as being a major contributor, although the details are not complete (Barrie *et al.*, 1988; Jobson *et al.*, 1994; Hausmann and Platt, 1994; Muthuramu *et al.*, 1994; Li *et al.*, 1994

\* Author to whom correspondence should be addressed.

McConnell *et al.*, 1992; Fan and Jacob, 1992; Tang and McConnell, 1996; Impey *et al.*, 1997b). In particular, although Impey *et al.* (1997b) found that significant concentrations of rapidly photolyzable bromine exist, it was not clear how the bromine was distributed among the possible forms, particularly HOBr and Br<sub>2</sub>, nor is it clear what the ultimate source of the photolytically active bromine is.

To improve our understanding of the halogen chemistry occurring in the Arctic troposphere, we have made measurements of photolyzable chlorine and bromine species using the photoactive halogen detector (PHD) as described in detail by Impey *et al.* (1997a), and bromine radicals using a modified radical amplifier, as part of the Polar Sunrise Experiment 1997. The photoactive halogen detector has been reconfigured to allow discrimination between halogens existing as HOX and X<sub>2</sub>. The simultaneous measurement of Br<sub>2</sub>, HOBr, and BrO<sub>x</sub> will allow us to investigate the role of O<sub>3</sub> in their interconversion, as well as to better understand the general polar sunrise O<sub>3</sub> depletion phenomenon and associated chemistry.

## 2. Experimental Procedures

The Polar Sunrise Experiment 1997 (PSE 97) was conducted at Alert, NWT, Canada (82.5°N, 62.3°W) from March 27 to April 11, 1997. Halogen measurements were made at the Special Studies Laboratory (SSL), situated on a plateau approximately 6 km SSW of the Canadian Forces Station, while ozone and meteorological data were measured continuously from the BAPMoN laboratory situated within 1 km of the SSL.

### 2.1 Photoactive Halogen Detector

The photoactive halogen detector is described in detail by Impey *et al.* (1997a). However, for this study, modifications were made in order to differentiate between halogens as X<sub>2</sub> and HOX which are believed to be the dominant photolytically active species in the Arctic (Fan and Jacob, 1992; Impey *et al.*, 1997b). Previous to this field campaign, the PHD operated as follows: ambient air is mixed with approximately 0.5 ppmv of each of propene (C<sub>3</sub>H<sub>6</sub>) and nitric oxide (NO) and drawn through a cylindrical reaction vessel, where it is irradiated with a Xe arc lamp. In the reaction vessel, photolytically active molecules such as Cl<sub>2</sub>, HOCl, Br<sub>2</sub> and HOBr are photolyzed to yield halogen atoms. These halogen atoms react with propene to form stable halogenated products including chloroacetone and bromoacetone, respectively. These products are then sampled and subsequently separated and detected by gas chromatography.

To differentiate between the two photolytically active halogen atom

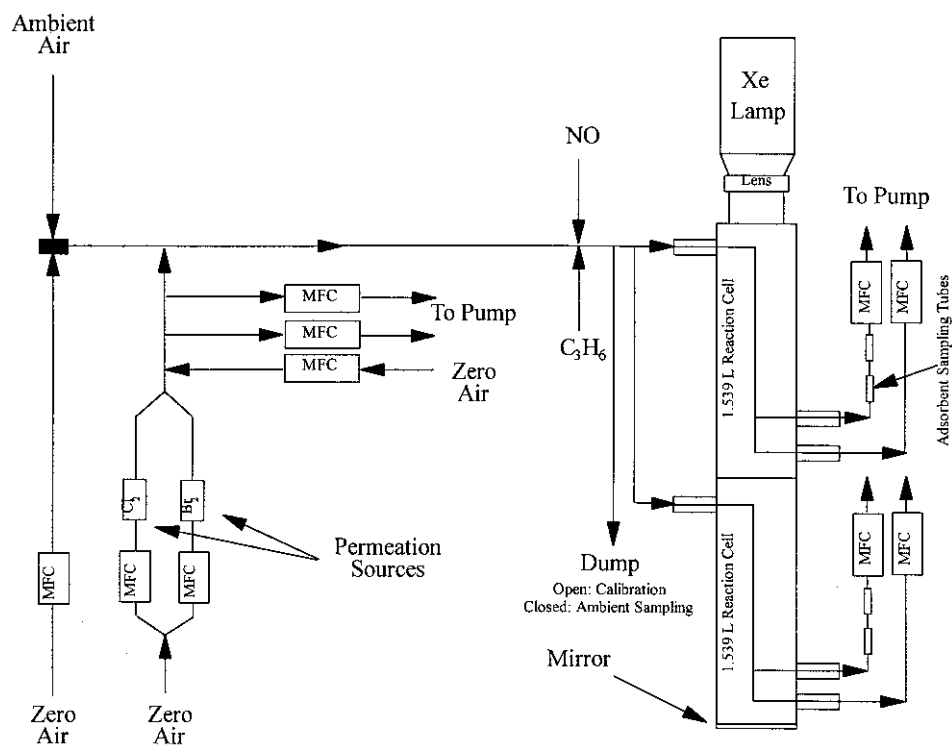

**Figure 1.** Schematic diagram of the photoactive halogen detector (PHD). (MFC = mass flow controller).

precursors (e.g.  $X_2$  and HOX) we use their significantly different photolysis rates (under cell conditions) by sampling simultaneously from two reactors with different residence times. To achieve this, the one cylindrical reaction cell was replaced by two independent cells separated by a quartz window (see Figure 1). Individual  $X_2$  and HOX ambient mixing ratios could then be determined by measurement of the product haloacetone concentration at two very different residence times and solving the following two equations:

$$[\text{haloacetone}]_{\tau_1} = \left( (1 - e^{-J_{X_2} \cdot \tau_1}) \times 2[X_2] + (1 - e^{-J_{HOX} \cdot \tau_1}) \times [HOX] \right) \alpha \quad \text{I}$$

$$[\text{haloacetone}]_{\tau_2} = \left( (1 - e^{-J_{X_2} \cdot \tau_2}) \times 2[X_2] + (1 - e^{-J_{HOX} \cdot \tau_2}) \times [HOX] \right) \alpha \quad \text{II}$$

where  $J$  is the photodissociation rate coefficient,  $\alpha$  is the yield of the haloacetone from the halogen atom reaction with propene, and  $\tau$  is the appropriate reactor residence time.

## 2.2 Photodissociation rate coefficient measurements

To obtain the X<sub>2</sub> and HOX concentrations using I and II above requires that the photodissociation rate coefficients for X<sub>2</sub> and HOX in the PHD are known. These were measured by following the photolysis of each of the 4 species (Cl<sub>2</sub>, HOCl, Br<sub>2</sub>, and HOBr) as a function of residence time in the cell. Gas phase samples of Cl<sub>2</sub> and Br<sub>2</sub> were generated from commercially available permeation sources. HOCl gas phase standards were prepared according to the procedure of Maben *et al.* (1995), and HOBr standards were prepared similarly. This procedure involved synthesis of aqueous solutions of HOCl (Taylor and Bostock, 1912) and HOBr (Branch and Jones, 1954). Gas phase samples were then obtained by bubbling N<sub>2</sub> through a large volume impinger filled with an appropriately diluted solution of HOCl (or HOBr) (Maben *et al.*, 1995). For a first order photolytic decay of species [A]:

$$[A]_t = [A]_0 \cdot e^{-J_A t} \quad \text{III}$$

where J<sub>A</sub> is the photolysis rate coefficient for compound A, [A]<sub>0</sub> is the input concentration, and [A]<sub>t</sub> is the concentration at the residence time t. Since [A]<sub>t</sub> = [A]<sub>0</sub> - Δ[A], the amount of A consumed is related to the concentration of the haloacetone product and the product yield α by:

$$[A]_t = \frac{[\text{haloacetone}]_{t \rightarrow \infty}}{\alpha} - \frac{[\text{haloacetone}]_t}{\alpha} \quad \text{IV}$$

The first order plot ln[A]<sub>0</sub>/[A]<sub>t</sub> versus t can be rearranged in terms of the haloacetone product to give:

$$\ln \frac{[A]_0}{[A]_t} = \ln \frac{[\text{haloacetone}]_{t \rightarrow \infty}}{[\text{haloacetone}]_{t \rightarrow \infty} - [\text{haloacetone}]_t} = J_A \cdot t \quad \text{V}$$

Thus individual J value measurements can be determined for the experimental system using the product haloacetone concentration independent of the product yield. A summary of Cl<sub>2</sub>, HOCl, Br<sub>2</sub>, and HOBr photodissociation rate coefficients as determined for the Alert experimental PHD cell conditions is shown in Table 1.

**Table 1.** Measured photodissociation rate coefficients under cell conditions.

Species (x)	J <sub>x</sub> Cell 1 (sec <sup>-1</sup> )	±	J <sub>x</sub> Cell 2 (sec <sup>-1</sup> )	±
Br <sub>2</sub>	0.064	0.006	0.035	0.004
HOBr	0.011	0.002	0.0054	0.0009
Cl <sub>2</sub>	0.0083	0.0003	0.0042	0.0005
HOCl	0.0039	0.0003	0.00198	0.00006

During the field campaign, cell 1 and cell 2 were operated alternately with residence times of 131.5 and 17 seconds. In this case, and using a yield of 0.80(±0.09), the detailed equations for bromine species for the case where cell 1 (C1) has a longer residence time than cell 2 (C2) are:

$$[\text{bromoacetone}]_{C1} = 1.60[\text{Br}_2]_{C1} + 0.61[\text{HOBr}]_{C1} \quad \text{VI}$$

$$[\text{bromoacetone}]_{C2} = 0.72[\text{Br}_2]_{C2} + 0.07[\text{HOBr}]_{C2} \quad \text{VII}$$

From these two equations the individual concentrations for Br<sub>2</sub> and HOBr can be determined from:

$$[\text{HOBr}] = \frac{(0.72 \cdot [\text{bromoacetone}]_{C1} - 1.60 \cdot [\text{bromoacetone}]_{C2})}{0.33} \quad \text{VIII}$$

$$[\text{Br}_2] = \frac{([\text{bromoacetone}]_{C1} - 0.61 \cdot [\text{HOBr}])}{1.60} \quad \text{IX}$$

### 2.3 Method Uncertainty

The uncertainties in the measured concentrations of X<sub>2</sub> and HOX consist of the uncertainties in the [haloacetone], and the measured photodissociation rate coefficients. It should be noted that the PHD can respond to XNO, XNO<sub>2</sub>, and XONO<sub>2</sub>. However, the levels of NO<sub>x</sub> in the Arctic at springtime have been found to be quite low (< 4.5 pptv) (Beine *et al.*, 1997), and we therefore assume that these species do not add any significant response. In the case of bromine, if 5 pptv of BrONO<sub>2</sub> were present, this would introduce an additional 5-10% error in the Br<sub>2</sub> and HOBr values.

### 2.4 Blanks and Detection Limits for the Photoactive Halogen Detector

Blank samples were generated using the same flows throughout the detector. Two types of blank samples were obtained, specifically involving either having the lamp on with zero air added at the inlet, or having the lamp off with ambient air. Estimation of the detection limit for a measurement was calculated using the standard deviation (SD) from the total number of blank determinations. The measured response from the PHD was in the form of chloroacetone and bromoacetone concentrations. All blank values were first converted to concentrations “as Cl<sub>2</sub>” and “as Br<sub>2</sub>”, respectively (based on the on-site calibration with known concentrations of Cl<sub>2</sub> and Br<sub>2</sub> mixtures in air), which could then be used as a measure for the detection limits of HOCl and HOBr (using the photodissociation rate coefficients under cell conditions to calculate equivalent concentrations as outlined in Impey *et al.*, (1997a)). The average SD<sub>blank</sub> for Cl<sub>2</sub> is 4.5 pptv and for Br<sub>2</sub> is 3.2 pptv. The detection limit at the 99% confidence level can then be expressed as 3 x SD<sub>blank</sub> or 14 pptv Cl<sub>2</sub>

(or 45 pptv HOCl) and 10 pptv Br<sub>2</sub> (or 25 pptv HOBr).

### 2.5 BrO<sub>x</sub> Radical Measurements

The sum of bromine atom (Br) and bromine monoxide (BrO) radicals, referred to as BrO<sub>x</sub> was measured using a modified radical amplifier. The standard RO<sub>x</sub> radical amplifier (Hastie *et al.*, 1991) allows the ambient radicals to react with added high concentrations of NO and CO in a flow reactor, and detects the resulting NO<sub>2</sub>. The standard radical amplifier chemistry then proceeds as follows:

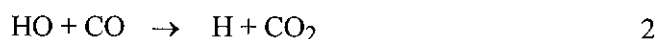
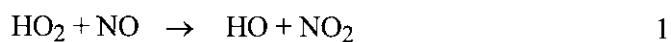

This chain reaction typically proceeds  $\approx 100$  times, producing measurable concentrations of NO<sub>2</sub>. The chain is terminated when radicals are lost to the reactor walls or through gas phase reactions, the most important of which is:

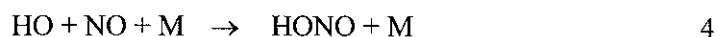

Organic peroxy radicals are also detected, since they are converted to HO<sub>2</sub> in the presence of NO in air:

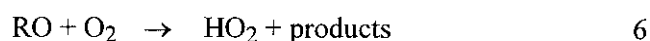
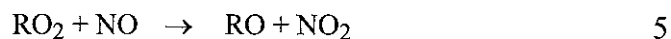

This allows determination of the sum of HO<sub>x</sub> (HO + HO<sub>2</sub>) radicals and a large fraction of the organic RO<sub>x</sub> (RO + RO<sub>2</sub>) radicals, but not the bromine or nitrate radicals.

The principle of the BrO<sub>x</sub> instrument is that any BrO<sub>x</sub> radical present is forced to react with an added hydrocarbon (in this case propene) in the presence of NO to produce a peroxy radical and then an HO<sub>2</sub> radical that can then be detected by the radical amplifier. The bromine specific chemistry is:

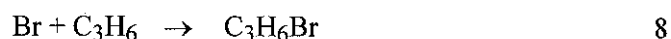
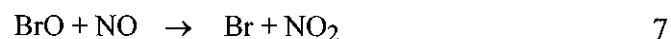

Most of the time, the species  $C_3H_5BrO$  is bromoacetone, as for the PHD chemistry. The difficulty with this system is to distinguish between the  $NO_2$  produced by this chemistry and that produced by  $RO_2$  or  $HO_2$  radicals, by chlorine radicals, by the reaction of ambient ozone with the added  $NO$  and the ambient  $NO_2$ . The key is to modulate the production of the  $HO_2$  radicals from the bromine so that a modulated  $NO_2$  concentration due to the presence of bromine radicals can be measured. This is done using the instrumental configuration shown in Figure 2.

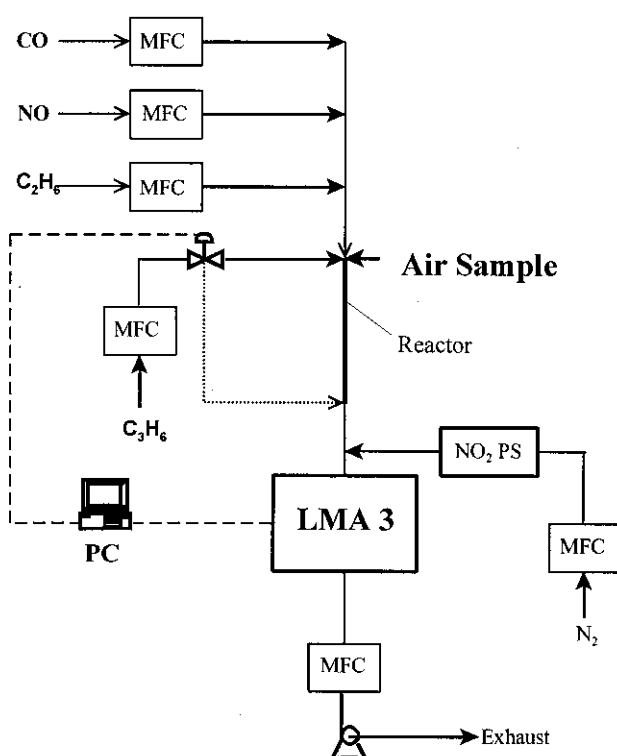

**Figure 2.** Schematic diagram of the  $BrO_x$  detector. (LMA =  $NO_2$  detector, MFC = mass flow controller, PS = permeation source).

The addition of  $CO$  and  $NO$  at the inlet will convert and amplify the  $RO_2$  and  $HO_2$  radicals to  $NO_2$  irrespective of the presence or absence of propene in the reactor. The addition of ethane will convert the chlorine radicals to  $RO_2$  radicals which are then amplified. It is essential to use the minimum amount of ethane and propene, as these hydrocarbons can react with the  $HO$  radicals in the reactor. The  $RO$  radicals produced can react with  $NO$  to produce organic nitrites, in competition with reactions analogous to reaction 5, thus lowering the

chain length. Therefore, [NO] should also not be too large.

When propene is added at the inlet of the instrument the bromine radicals are converted to HO<sub>2</sub> radicals, which are then amplified. Alternatively, when propene is added downstream of the inlet the Br produced in reaction 11 continue to react via reaction 12, to produce BrNO which is likely stable in the system (which is dark).



Under this condition, no radicals remain in the system at the point of C<sub>3</sub>H<sub>6</sub> addition. The details of the chemistry occurring when the propene is added at the two positions is shown in Table 2 below.

Table 2. BrO<sub>x</sub> amplifier system condition states.

Propene added downstream. NO <sub>2</sub> results from:	Propene added at inlet. NO <sub>2</sub> results from:
Ambient NO <sub>2</sub>	Ambient NO <sub>2</sub>
Ambient O <sub>3</sub>	Ambient O <sub>3</sub>
Amplification of RO <sub>x</sub> radicals	Amplification of RO <sub>x</sub> radicals
Amplification of ClO <sub>x</sub> radicals	Amplification of ClO <sub>x</sub> radicals
-	Amplification of BrO <sub>x</sub> radicals

The concentration of BrO<sub>x</sub> is calculated using the NO<sub>2</sub> produced, the conversion efficiency of BrO<sub>x</sub> to HO<sub>2</sub> (the transformation yield TY) and the chain length for HO<sub>x</sub> detection (CL) by:

$$[\text{BrO}_x] = \frac{\Delta[\text{NO}_2]}{\text{CL} \cdot \text{TY}} \quad \text{X}$$

The chain length was determined daily throughout the campaign using an HO<sub>x</sub> source based on the photolysis of water in the presence of CO (Schultz *et al.*, 1995). The transformation yield depends on the details of the chemistry and should be a constant. Therefore, it was determined in the laboratory using a variation of the water vapour radical source. Approximately 1-2 ppmv of Br<sub>2</sub> was added to the output of the radical source. This converted some of the HO radicals to bromine atoms through reaction 13 ( $k_{13}=4.5 \times 10^{-11} \text{cm}^3 \text{molecule}^{-1} \text{s}^{-1}$ , Atkinson *et al.*, 1997):

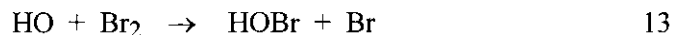

In the standard radical detector this results in a decrease in radical signal. Restoring the propene so the system also measures BrO<sub>x</sub> radicals allows the transformation yield of BrO<sub>x</sub> to be determined. The yield was found to be  $0.9 \pm 0.1$ , and this was used for all measurements.

### 2.6 Detection Limits for the BrO<sub>x</sub> radical detector

The detection limit for the bromine radical detector was estimated using the data collected during Days 89-90, even though some bromine radicals seem to be present. The detection limit, calculated as 3 SD<sub>blank</sub>, was 4 pptv.

As an aside we note that we attempted to develop a version of this detector to measure ClO<sub>x</sub> radicals, by removing the propene and modulating the position at which the ethane is added. However, recent results of Hewitt *et al.*, (1996) on reaction 16 and the reasonable postulate that reaction 17 proceeds analogously to the peroxy acetyl radical reaction with NO, led to the conclusion that ClO<sub>x</sub> radicals undergo a chain reaction with CO and NO (Reactions 14-17 below):

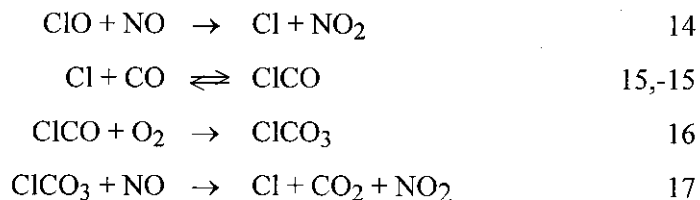

This chemistry makes ClO<sub>x</sub> radicals indistinguishable from RO<sub>x</sub> radicals in the standard radical amplifier and prevented the development of a chlorine specific detector.

### 3. Results and Discussion

Measurements of ozone, solar radiation, and the halogen compounds indicated above were made for the period March 27 to April 11 (Days 86-101), 1997. The data are shown in Figures 3-5. Measurements of photolyzable chlorine (Figure 3) during the whole sampling period were either low or below the detection limit of the instrument (14 pptv measured "as Cl<sub>2</sub>"), consistent with our previous findings for the time period of these measurements (Impey *et al.*, 1997b). Therefore individual Cl<sub>2</sub> and HOCl concentrations could not be determined. Detectable photolyzable chlorine existed only under conditions of partial O<sub>3</sub> depletion, implying that O<sub>3</sub> is required for Cl<sub>2</sub> production. However there were significant concentrations of photolyzable bromine present, present both as Br<sub>2</sub> and HOBr. Measured ground level ozone, Br<sub>2</sub> and HOBr are shown in Figure 4. The uncertainties in these mixing ratios are included (error bars). The uncertainties do not include the possibility that significant concentrations of BrNO, BrNO<sub>2</sub>, and BrONO<sub>2</sub> could be present (as discussed in section 2.3). If 5 pptv of BrONO<sub>2</sub> is available, the impact on the uncertainties in the levels of Br<sub>2</sub> and HOBr is an additional 5-10% error on these values.

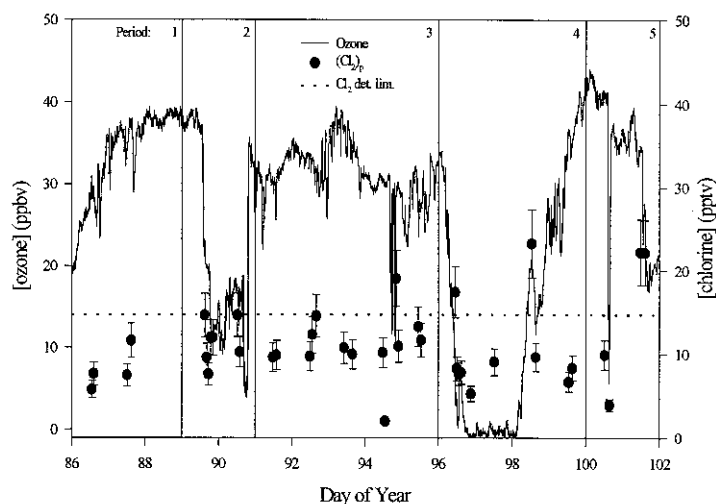

**Figure 3.** Comparison of ground level ozone and photolyzable chlorine as  $\text{Cl}_2$ , measured at Alert.

The observations can be separated into 5 distinct periods (see Figures 3-5) based on the ozone concentration: 1) days 86-89 where ozone is typically between 30 and 40 ppb; 2) days 89-91, a minor ozone depletion event where ozone was  $\sim 10$  ppb; 3) days 91-96, again typical background ozone levels; 4) days 96-100; a significant ozone depletion episode in which ozone concentrations drop below the detection limit of the instrument; and finally 5) days 100-101, recovery from depleted levels.

The bromine data are variable even for the “normal” ozone conditions. In period 1 both the PHD and  $\text{BrO}_x$  data are either at or below the detection limits. In period 3 the PHD shows no  $\text{Br}_2$  or HOBr but the  $\text{BrO}_x$  concentrations are above the detection limit towards the end of the period. In period 5 only  $\text{BrO}_x$  was above the detection limit. Hence there is evidence for bromine under apparently normal ozone conditions. The  $\text{BrO}_x$  data are plotted in Figure 5, along with the UV radiation. It is interesting to note that although there appears to be a correlation of  $\text{BrO}_x$  with radiation (particularly for Day 98), there are also periods, e.g. near midnight on Day 95/96, when  $\text{BrO}_x$  is detected when radiation levels are low. During the major depletion episode (period 4) the PHD shows evidence for  $\text{Br}_2$  at the beginning (similar for the minor ozone depletion episode of period 2) and during the event, and very large amounts of HOBr at the end of the period (the concentration of  $\text{Br}_2$  at the end of the period 4

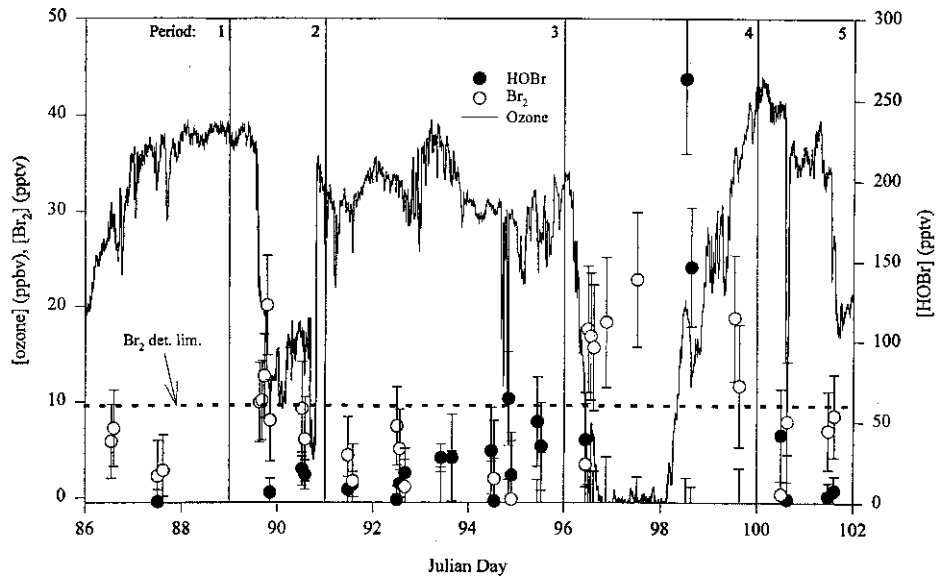

Figure 4. Comparison of ground level ozone,  $\text{Br}_2$  and HOBr concentrations measured at Alert.

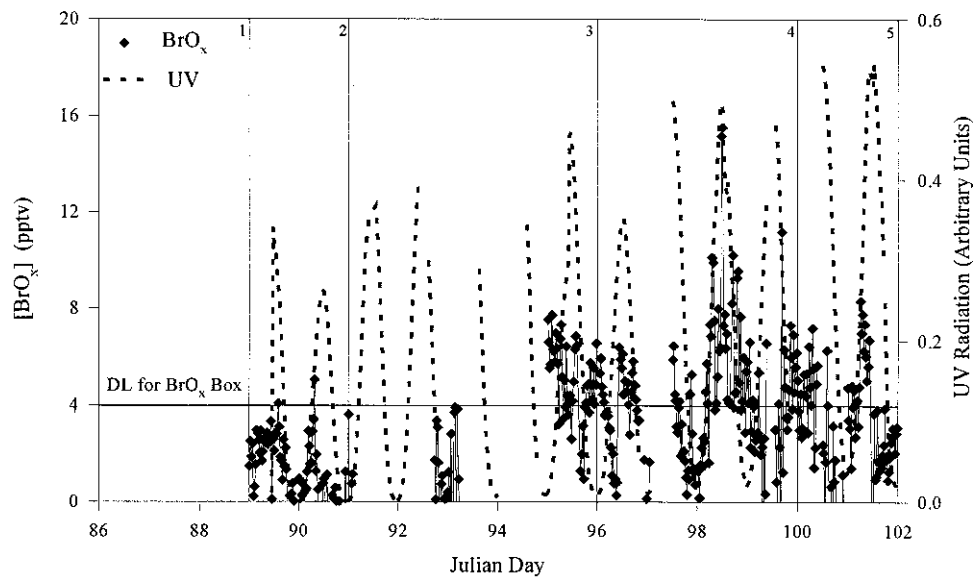
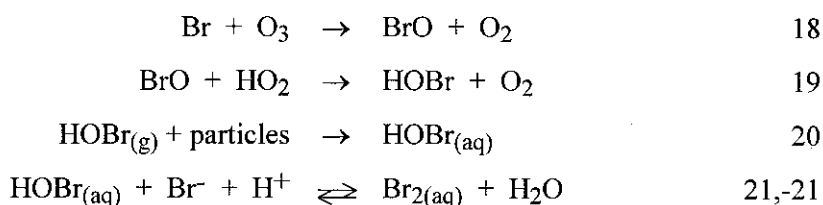

Figure 5.  $\text{BrO}_x$  concentration and UV radiation measured at Alert.

depletion event is below the detection limit of the PHD). The presence of Br<sub>2</sub> when O<sub>3</sub> is near zero concentration (see mid Day 97) indicates that Br<sub>2</sub> can be recycled by some mechanism that does not involve O<sub>3</sub>, i.e. that does not involve HOBr. It has been proposed by Fan and Jacob (1992) that the O<sub>3</sub> destruction cycle may involve heterogeneous phase Br<sub>2</sub> regeneration via reactions 18-21, followed by efflux of Br<sub>2</sub> from the aerosol phase, and photolysis of Br<sub>2</sub> to regenerate Br atoms.



However, in the absence of O<sub>3</sub>, HOBr is not produced (consistent with the data shown in Figure 4 for Day 97), since BrO radical concentrations are necessarily low (see the data for Day 97 in Figure 6; interestingly, there does appear to be detectable levels of BrO<sub>x</sub> on Day 97, in the absence of O<sub>3</sub>, which is most likely to be Br atoms from the photolysis of Br<sub>2</sub>), and thus this recycling mechanism cannot operate. There must then be an alternate mechanism that generates Br<sub>2</sub>. Although we previously reported that there must be a dark mechanism that generates Br<sub>2</sub> (Impey *et al.*, 1997b), possibly involving O<sub>3</sub>, there must also be a mechanism in the light period for oxidation of Br<sup>-</sup> that does not operate via reaction 21. Oum *et al.* (1998) suggested that molecular chlorine is formed through the reaction of sea-salt chloride and the photolysis of ozone, and that this chemistry also works for bromine. Thus there may be aqueous phase chemistry involving oxidants other than HOBr, possibly involving peroxy monosulfuric acid, as discussed by Mozurkewich (1995).

The highest BrO<sub>x</sub> levels were observed at the end of period 4, as O<sub>3</sub> recovered, although there is a great deal of variability in the levels. The highest concentration of 15 pptv is consistent with the findings of Hausmann and Platt (1994), and occurs simultaneously with the maximum in the HOBr concentration. This is not surprising, since HOBr is produced from BrO radicals, in reaction 19. A likely important source of HO<sub>2</sub> is the photolysis of HCHO, which is present at 200-300 pptv at this time (Sumner and Shepson, 1998). It is also possible that HO<sub>2</sub> is partly sustained from Cl atom reaction with hydrocarbons (Jobson *et al.*, 1994).

In 1995 the first measurements of photolyzable halogens were made and significant concentrations of bromine were identified. However, until now the distribution of photolyzable bromine between Br<sub>2</sub> and HOBr was speculative. In Figure 6, simultaneous measurements of HOBr and BrO<sub>x</sub> show

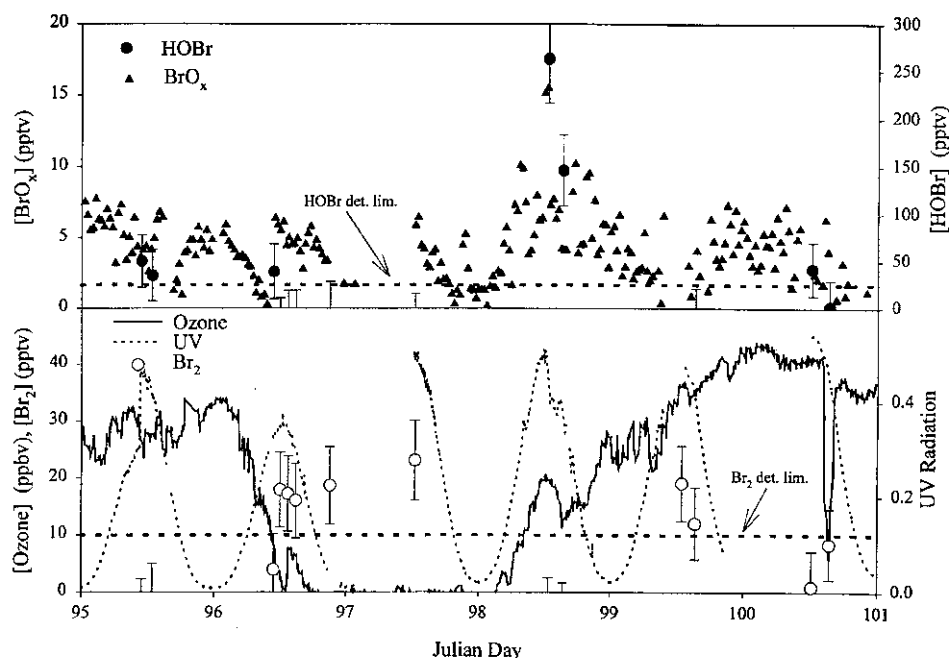

**Figure 6.** Comparison of ground level ozone, HOBr, BrO<sub>x</sub>, and Br<sub>2</sub> measured at Alert. Expanded view of Julian Days 95-101 (period 4).

significant correlation to each other, and a large increase as ozone returns to normal levels, i.e. when the sampled Arctic boundary layer air is thought to mix with air derived from the free troposphere. This implies that the photolytically active Br atom precursors are present in the Arctic Ocean air, but that the chain length, and thus BrO<sub>x</sub> radical concentrations are low, due to Br atom termination, likely via reaction with HCHO and CH<sub>3</sub>CHO (Shepson *et al.*, 1996). However, when O<sub>3</sub> is present, allowing conversion of Br to BrO, rather than Br atom termination, BrO<sub>x</sub> and HOBr levels increase.

For Day 98, it is possible to calculate the HO<sub>2</sub> radical concentration necessary to sustain the observed level of HOBr, given the measured BrO<sub>x</sub>, which we assume to be all BrO, since [Br] is estimated to be on the order of 0.3 pptv (Jobson *et al.*, 1994). This can be done by applying the steady state assumption to HOBr. At noon, we calculate the peak  $J_{HOBr}$  to be  $4.5 \times 10^{-4} \text{ s}^{-1}$  (Tang and McConnell, 1996). HOBr is also lost to the aerosol phase, where we estimate for the aerosol burden at Alert that  $k_{20} = 1.4 \times 10^{-4} \text{ s}^{-1}$  (Shepson *et al.*, 1996). Assuming only these two loss processes for HOBr leads to an HOBr lifetime  $\tau_{HOBr} = 28 \text{ min}$ . We can thus calculate  $[HOBr]_{ss}$  as indicated in equation XI:

$$[HOBr]_{ss} = \frac{k_{19} \cdot [HO_2][BrO]}{J_{HOBr} + k_{20}} \quad \text{XI}$$

$$[HO_2] = \frac{(J_{HOBr} + k_{20}) \cdot [HOBr]}{k_{19}[BrO]} \quad \text{XII}$$

For midday on Day 98, the  $[HOBr]/[BrO]$  ratio is  $\approx 17$ . Given  $k_{19} = 5.0 \times 10^{-11} \text{ cm}^3 \text{ molecule}^{-1} \text{ s}^{-1}$  (Atkinson *et al.*, 1997), we obtain  $[HO_2]_{ss} = 6 \text{ pptv}$ . Impey *et al.* (1997b) simulated the  $[HO_2]$  to be on the order of 1 pptv when the ratio of  $[HOBr]/[BrO]$  is  $\approx 0.3$ . Similarly, Le Bras (1993) simulated  $[HO_2] = 0.8 \text{ pptv}$  for Arctic springtime conditions. This may in part be related to the fact that all models of the Arctic underestimate HCHO, which is likely a significant  $HO_2$  source via its photolysis.

Although the ratio  $[HOBr]/[Br_2]$  is large in the Arctic Ocean air mass, e.g. perhaps on the order of 10 (i.e. 200 pptv HOBr, 20 pptv  $Br_2$ ),  $Br_2$  is nonetheless much more important than HOBr as a direct Br atom source. For this level of  $Br_2$ , and  $J_{Br_2} = 0.010 \text{ s}^{-1}$  (Tang and McConnell, 1996), Br atoms would be produced at a rate equal to 24 pptv/min., while HOBr photolysis for 200 pptv, and using  $J_{HOBr} = 4.5 \times 10^{-4} \text{ s}^{-1}$ , yields a Br atom production rate of only 5 pptv/min.

It is important to note that the SSL site at Alert is at 210 m above sea level and is located about 6 km from the Arctic Ocean shoreline. It is known that the depletion events are associated with air arriving at Alert from the ocean (Bottenheim *et al.*, 1990). Thus, measurements made during what appears to be the complete disappearance of ozone (e.g. for Day 97), may reflect chemistry that occurred as much as several days previously. Thus one cannot directly relate the observed BrO or  $Br_2/HOBr$  at Alert to conditions that existed while ozone depletion was occurring. However, this is not the case as  $O_3$  is recovering. Under these conditions,  $O_3$  from above the low lying ( $\approx 400 \text{ m}$ ) Arctic inversion mixes down to the surface. This normally occurs under southerly flow conditions. These are the conditions that existed for Day 98 when HOBr and  $BrO_x$  levels maximized. Because of the short lifetime of these species, they must have been produced locally, rather than having been derived from the Arctic Ocean. It thus seems likely that they were derived from oxidation chemistry that occurred on the surface of the snowpack, e.g. involving deposited sea salt from aerosols. Clearly, fluxes of photolytically active halogen species should be measured from the Arctic snow pack.

Given the current information, it does appear that  $Cl_2$  and  $Br_2$  are derived from the surface (Impey *et al.*, 1997b). The total photolyzable chlorine measured "as  $Cl_2$ " gives us an upper limit for the  $[Cl_2]$  of 17 pptv (Day 96.4; Figure 3) and the measured  $[Br_2]$  of 18 pptv (observed 1 hour later, Figure 4). We can thus estimate the relative fluxes of these compounds using the general reactions 22 and 23.



This leads to equation XIII for the calculation of the  $X_2$  flux:

$$k_{22} = J_{X_2} \cdot [X_2] \quad \text{XIII}$$

Given that the photodissociation rate coefficient for this time is calculated to be 10 times greater for  $\text{Br}_2$  ( $J_{\text{Br}_2} = 0.01\text{s}^{-1}$ ) than that for  $\text{Cl}_2$  ( $J_{\text{Cl}_2} = 1 \times 10^{-3}\text{s}^{-1}$ ), the calculated  $\text{Br}_2$  flux is therefore correspondingly greater. We calculate volumetric fluxes of 650 pptv/hr and 61 pptv/hr for  $\text{Br}_2$  and  $\text{Cl}_2$ , respectively.

To examine more closely the origin of high concentrations of photolytically active bromine, three-day back trajectory analysis indicates the sample air arriving from the Arctic Ocean region, as mentioned above and similar to observations in PSE 1995. We plotted the results as polar plots of [bromine] (total photolyzable bromine measured "as  $\text{Br}_2$ ") versus the trajectory origin sector. The average concentration was determined within eight equal  $45^\circ$  intervals that were arbitrarily divided. The results are presented in Figure 7.

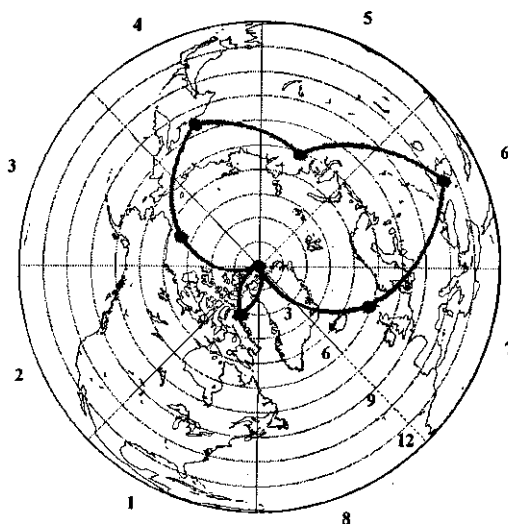

Figure 7. Average bromine concentration by sector region.

On average the higher bromine concentrations were observed for air parcels arriving at Alert from sectors 4, 5, 6, and 7. Of the four sections mentioned,

sector 6 contained the highest concentrations which is also consistent with observations made in 1995 (Impey *et al.*, 1997b). No trajectory analysis was done for chlorine as most of the data was at or below the detection limit of the instrument.

#### 4. Conclusions

This work provides conclusive evidence for the presence of substantial concentrations of HOBr and BrO in the Arctic during the time of polar sunrise and an ozone depletion event. Additionally, we conclude that high levels of Br<sub>2</sub> are likely derived from processes occurring at the snow pack surface, as the peak concentrations only appear at the end of an ozone depletion episode, when the air mass origin is from the south. It seems clear that measurement of fluxes of trace gases, such as Br<sub>2</sub> and Cl<sub>2</sub>, should be determined from the snow pack.

#### Acknowledgements

We thank NSERC and AES for their financial and logistical support and D. Worthy for back trajectories.

#### References

- Atkinson, R., Baulch, D.L., Cox, R.A., Hampson Jr, R.F., Kerr, J.A., Rossi, M.J., and Troe, J., 1997: Evaluated Kinetic, Photochemical and Heterogeneous Data for Atmospheric Chemistry: Supplement V, *J. Phys. Chem. Ref. Data*, Vol. 26, No. 3.
- Barrie, L.A., Bottenheim, J.W., Schnell, R.C., Crutzen, P.J., and Rasmussen, R.A., 1988: Ozone destruction and photochemical reactions at polar sunrise in the lower Arctic atmosphere, *Nature*, **334**, 138-141.
- Beine, H.J., Jaffe, D.A., Stordal, F., Engardt, M., Solberg, S., Schmidbauer, N., and Holmen, K., 1997: NO<sub>x</sub> During Ozone Depletion Events in the Arctic Troposphere at Ny-Ålesund, Svalbard, *Tellus*, **49B**, 556-565.
- Bottenheim, J.W., Gallant, A.G., and Brice, K. A., 1986: Measurements of NO<sub>y</sub> species and O<sub>3</sub> at 82° N latitude, *Geophys. Res. Lett.*, **13**, 113-116.
- Bottenheim, J.W., Barrie, L.A., Atlas, E., Heidt, L.E., Niki, H., Rasmussen, R.A. and Shepson, P.B., 1990: Depletion of Lower Tropospheric Ozone During Arctic Spring: The Polar Sunrise Experiment 1988, *J. Geophys. Res.*, **95**, 18555-18568.
- Branch, S.J., and Jones, B., 1954: Kinetics and Mechanism of Aromatic Halogenation by Hypohalous Acids. Part I. Bromination of Aromatic Ethers by Hypobromous Acid, *J. Chem. Soc.*, 2317-2324.
- Fan, Song-Miao and Jacob, D.J., 1992: Surface ozone depletion in Arctic spring sustained by at bromine reactions on aerosols, *Nature*, **359**, 522-524.
- Hastie, D. R., Weissenmayer, M., Burrows, J. P., and G. W. Harris, G. W., 1991: Calibrated Chemical Amplifier for atmospheric RO<sub>x</sub> measurements, *Anal. Chem.*, **63**, 2048-2057.
- Hausmann, M., and Platt, U., 1994: Spectroscopic Measurement of Bromine Oxide in the High Arctic During Polar Sunrise Experiment 1992, *J. Geophys. Res.*, **99**, 25,399-25,413.

- Hewitt, A.D., Brahan, K.H., Boone G.D., Hewitt, S.A., 1996: Kinetics and mechanism of Cl + CO reaction in air, *Intern. J. of Chem. Kinet*, **28**, 763-771.
- Impey, G.A., Shepson, P.B., Hastie, D.R., Barrie, L.A., 1997a: Measurement Technique for the Determination of Photolyzable Chlorine and Bromine in the Atmosphere, *J. Geophys. Res.*, **102**, 15999-16004.
- Impey, G.A., Shepson, P.B., Hastie, D.R., Barrie, L.A., Anlauf, K.G., 1997b: Measurements of Photolyzable Chlorine and Bromine Sources During the Polar Sunrise Experiment 1995, *J. Geophys. Res.*, **102**, 16005-16010.
- Jobson, B.T., Niki, H., Yokouchi, Y., Bottenheim, J.W., Hopper, F. and Leaitch, R., 1994: Measurements of C<sub>2</sub>-C<sub>6</sub> Hydrocarbons During the 1992 Polar Sunrise Experiment: Evidence of Cl-atom and Br-atom Chemistry, *J. Geophys. Res.*, **99**, 25,355-25,368.
- Le Bras, G., 1993: Reaction of BrO radicals Relevant to Polar Chemistry, in *Global Environmental Change* vol. 7 edited by H. Niki and K.H. Becker, pp. 397-404. Springer-Vaerlag, New York.
- Li, S.M., Yokouchi, Y., Barrie, L.A., Muthuramu, K., Shepson, P.B., Bottenheim, J.W., Sturges, W.T. and Landsberger, S., 1994: Organic and Inorganic Bromine Compounds and their Composition in the Arctic Troposphere During Polar Sunrise, *J. Geophys. Res.*, **99**, 25,415-25,428.
- Maben, J.R., Keene, W.C., Pszenny, A.A.P., and Galloway, J.N., 1995: Volatile Inorganic Cl in Surface Air Over Eastern North America, *Geophys. Res. Lett.*, **22**, 3513-3516.
- McConnell, J.C., Henderson, G.S., Barrie, L.A., Bottenheim, J.W., Niki, H., Langford, C.H., Templeton, E.M., 1992: Photochemical Bromine Production Implicated in Arctic Boundary-Layer Ozone Depletion, *Nature*, **355**, 150-152.
- Mozurkewich, M., 1995: Mechanisms for the release of halogens from sea-salt particles by free radical reactions, *J. Geophys. Res.*, **100**, 14,199-14,207.
- Muthuramu, K., Shepson, P.B., Bottenheim, J.W., Jobson, B.T., Niki H., and Anlauf, K.G., 1994: Relationships Between Organic Nitrates and Surface Ozone Destruction During Polar Sunrise Experiment 1992, *J. Geophys. Res.*, **99**, 25,369-25, 378.
- Oum, K.W., Lakin, M.J., DeHaan, D.O., Brauers, T., and Finlayson-Pitts, B.J., 1998: Formation of Molecular Chlorine from the Photolysis of Ozone and Aqueous Sea-Salt Particles, *Science*, **279**, 74-77.
- Schultz, M., Heitlinger, M., Mihelcic, D., and Volz-Thomas, A., 1995: Calibration source for peroxy radicals with built-in actinometry using H<sub>2</sub>O and O<sub>2</sub> photolysis at 185nm, *J. Geophys. Res.*, **100**, 18,811-18,816.
- Sumner, A. L. and Shepson, P. B., 1998: Formaldehyde in the Arctic Troposphere at Polar Sunrise, submitted to *Nature*.
- Taylor, R.L., and Bostock, C., 1912: Researches on Bleaching Powder: Part II. The Action of Dilute Acids on Bleaching Powder, *J. Chemical Society*, **101**, 444-457.
- Tang, T., and McConnell, J.C., 1996: Autocatalytic Release of Bromine from Arctic Snow Pack During Polar Sunrise, *Geophys. Res. Lett.*, **23**, 2633-2636.